

2.2 Thermal Processes

Question Paper

Level	IGCSE
Subject	Physics (0625)
Exam Board	Cambridge International Examinations(CIE)
Topic	Thermal Physics
Sub Topic	2.2 Thermal Processes
Booklet	Question Paper

Time Allowed: 52 minutes

Score: /43

Percentage: /100

Grade Boundaries:

A*	A	B	C	D	E	U
>85%	75%	60%	45%	35%	25%	<25%

- 1 A substance loses thermal energy (heat) to the surroundings at a steady rate.

The graph shows how the temperature of the substance changes with time.

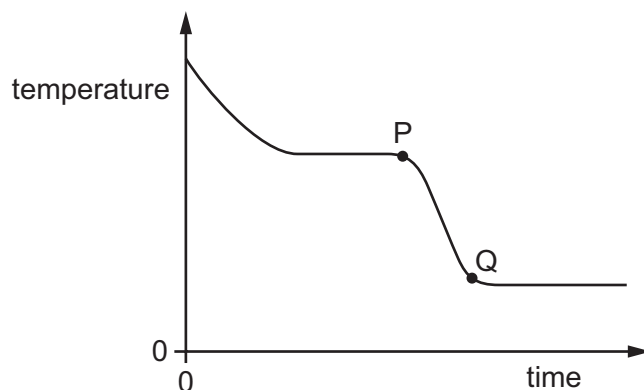

What could the portion PQ of the graph represent?

- A gas condensing
 - B gas cooling
 - C liquid cooling
 - D liquid solidifying
- 2 Two otherwise identical cars, one black and one white, are at the same initial temperature. The cars are left in bright sunshine and their temperatures increase. During the night their temperatures decrease.

Which car shows the greater rate of temperature increase and which car shows the greater rate of temperature decrease?

	greater rate of temperature increase	greater rate of temperature decrease
A	black	black
B	black	white
C	white	black
D	white	white

- 3 A beaker of liquid is left on a laboratory bench. There is an electric fan in the laboratory causing a draught over the liquid.

The liquid evaporates.

Which row shows two changes that will **both** cause the liquid to evaporate more quickly?

	change to surface area of the liquid	change to speed of fan
A	decrease	decrease
B	decrease	increase
C	increase	decrease
D	increase	increase

- 4 Which processes occur in a metal to cause thermal conduction?

	electron transfer	proton transfer	lattice vibration
A	✓	✓	✓
B	✓	✓	x
C	✓	x	✓
D	x	✓	✓

key

✓ = process occurs

x = process does not occur

- 5 A wooden beam is painted part black and part white. The beam absorbs infra-red radiation from the Sun during the day, and loses infra-red radiation to the surroundings at night.

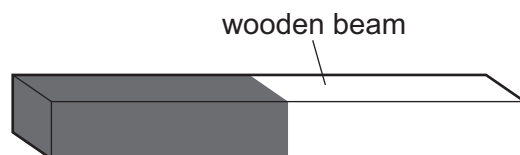

Which part of the beam heats up more quickly during the day, and which part cools down more quickly at night?

	part heating up more quickly	part cooling down more quickly
A	black	black
B	black	white
C	white	black
D	white	white

- 6 Which row shows the surface that is the better absorber and the surface that is the better emitter of infra-red radiation?

	better absorber	better emitter
A	black surface	black surface
B	black surface	white surface
C	white surface	black surface
D	white surface	white surface

- 7 A student suggests some uses for containers made from good thermal conductors and for containers made from poor thermal conductors.

In which row are both suggested uses correct?

	good thermal conductor	poor thermal conductor
A	keeping a cold liquid at a low temperature	transferring thermal energy quickly from a hot liquid
B	keeping a hot liquid at a high temperature	keeping a cold liquid at a low temperature
C	transferring thermal energy quickly from a hot liquid	transferring thermal energy quickly to a cold liquid
D	transferring thermal energy quickly to a cold liquid	keeping a hot liquid at a high temperature

- 8 One end of a copper rod is heated.

What is one method by which thermal energy is transferred in the copper rod?

- A** Free electrons transfer energy from the cooler end to the hotter end.
- B** Free electrons transfer energy from the hotter end to the cooler end.
- C** Molecules of copper move from the cooler end to the hotter end.
- D** Molecules of copper move from the hotter end to the cooler end.

- 9 Two plastic cups are placed one inside the other. A small spacer keeps the two cups separated.

Hot water is poured into the inner cup and a lid is put on top, as shown.

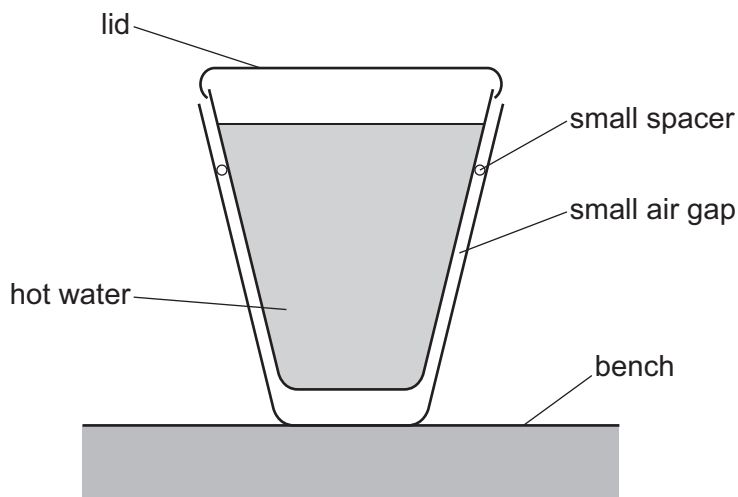

Which statement is correct?

- A The bench is heated by convection from the bottom of the outer cup.
 - B The lid reduces the energy lost by convection.
 - C There is no thermal conduction through the sides of either cup.
 - D Thermal radiation is prevented by the small air gap.
- 10 The diagram shows some ice being used to lower the temperature of some warm water.

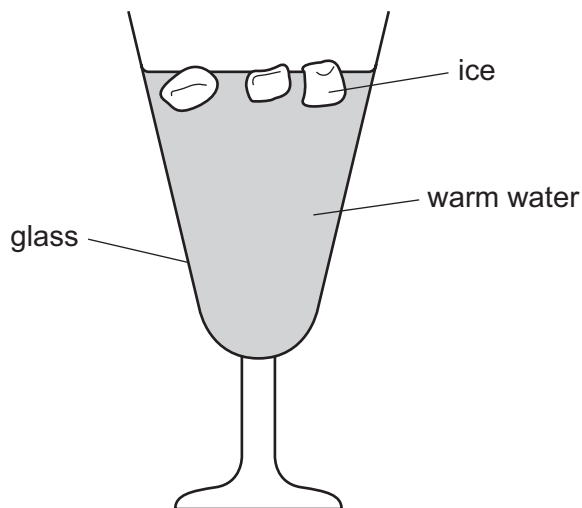

What is the main process by which the water at the bottom of the glass becomes cool?

- A condensation
- B conduction
- C convection
- D radiation

- 11 A solid is heated from room temperature.

The graph shows how its temperature changes with time as it is heated constantly.

At which time has it just become **completely** liquid?

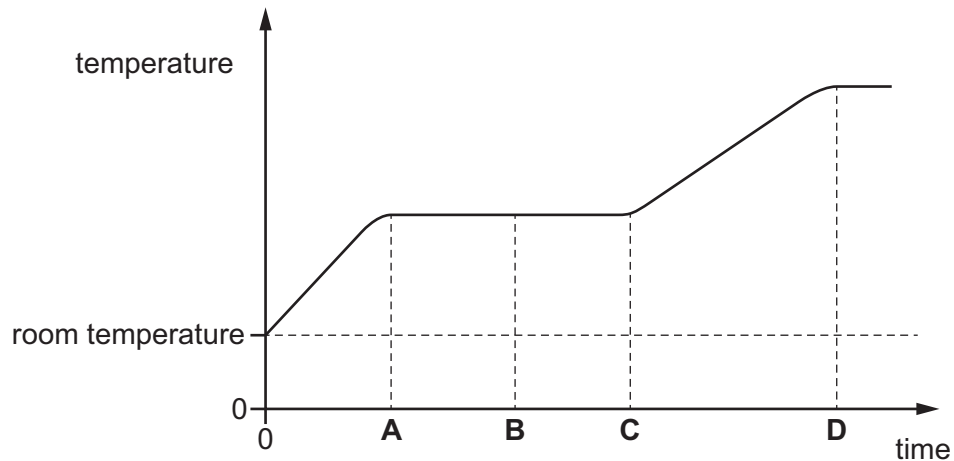

- 12 Thermal energy travels through space from the Sun to the Earth. Space is a vacuum.

How is thermal energy transferred from the Sun to the Earth?

- A by conduction only
- B by convection only
- C by radiation only
- D by convection and radiation

13 The diagram shows a vacuum flask used to keep liquid hot.

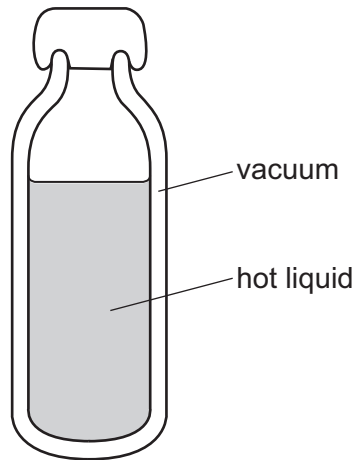

How does thermal energy pass through the vacuum?

- A conduction only
- B convection only
- C radiation
- D conduction and convection

- 14 A cupboard is placed in front of a heater. Air can move through a gap under the cupboard.

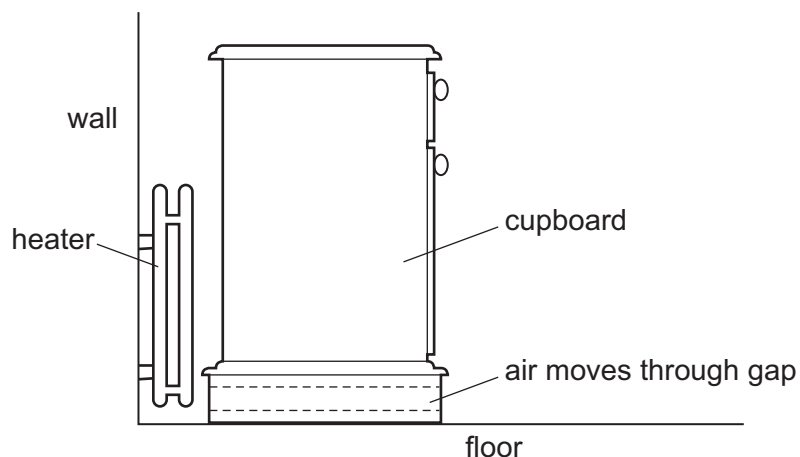

Which row describes the temperature, and the direction of movement, of the air in the gap?

	air temperature	air direction
A	cool	away from the heater
B	cool	towards the heater
C	warm	away from the heater
D	warm	towards the heater

- 15 One method of heat transfer involves the energy travelling at a much greater speed than in other methods.

What is the name of this method?

- A** conduction
- B** convection
- C** evaporation
- D** radiation

- 16 A cupboard is placed in front of a heater. Air can move through a gap under the cupboard.

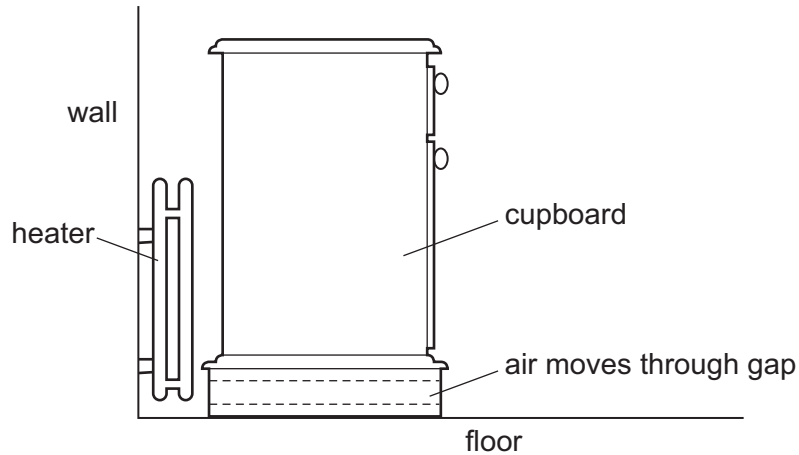

Which row describes the temperature, and the direction of movement, of the air in the gap?

	air temperature	air direction
A	cool	away from the heater
B	cool	towards the heater
C	warm	away from the heater
D	warm	towards the heater

- 17 The air in a room is heated by a heater. The diagram shows the circulation of the air in the room.

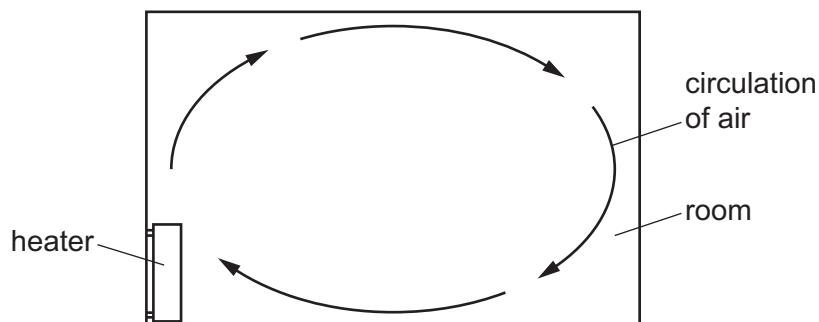

Which statement about the air that is heated is correct?

- A** The air contracts and becomes less dense.
- B** The air contracts and becomes more dense.
- C** The air expands and becomes less dense.
- D** The air expands and becomes more dense.

- 18 Four rods are made from different metals P, Q, R and S. The rods have equal lengths and equal diameters. The rods are heated at one end, in the same way.

The table shows the time taken for the temperature at the other end of each rod to rise by 1.0°C .

Which metal is the best conductor of thermal energy (heat)?

metal	time taken/s
P	35
Q	30
R	45
S	40

- A** metal P **B** metal Q **C** metal R **D** metal S
- 19 In a refrigerator, the cooling unit can be fitted either at the top or at the bottom. In an oven, the heater can be fitted either at the top or at the bottom.

Which row shows the best position for the cooling unit and the best position for the heater?

	cooling unit	heater
A	bottom	bottom
B	bottom	top
C	top	bottom
D	top	top

- 20 A girl is outdoors. She warms her hands by holding them near a fire, as shown.

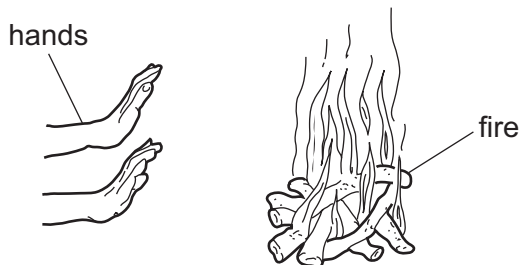

How does the heat from the fire reach her hands?

- A** conduction only
B convection and conduction
C convection and radiation
D radiation only

- 21 A heating engineer fits a heater to the ceiling of an office so that workers in the office are kept warm.

How does thermal energy reach the workers below the heater?

- A conduction and convection
 - B convection and radiation
 - C convection only
 - D radiation only
- 22 Which row shows how heating changes the density of air, and the name of the method of energy transfer caused by this density change?

	density	method of energy transfer
A	decreases	conduction
B	decreases	convection
C	increases	conduction
D	increases	convection

- 23 What is the name of the process of heat transfer using electromagnetic waves?

- A conduction
- B convection
- C evaporation
- D radiation

24 Ice is trapped by a metal gauze at the bottom of a tube containing water.

The water is heated strongly at the top, but the ice only melts very slowly.

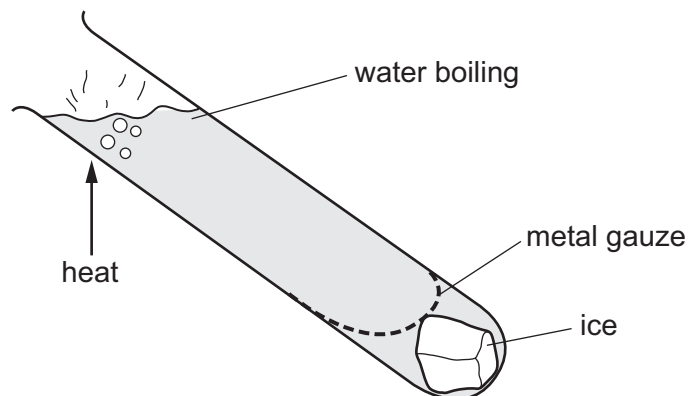

Why does the ice melt so slowly?

- A Heat energy always travels upwards.
 - B Hot water is more dense than cold water.
 - C Metal gauze does not allow heat to pass through.
 - D Water is a poor conductor of heat.
- 25 Which statement about the transfer of thermal energy is correct?
- A All metals conduct thermal energy equally well.
 - B Convection can only occur in solids or liquids.
 - C Convection occurs in liquids because hot liquid is more dense than cold liquid.
 - D The radiation that transfers thermal energy is a type of electromagnetic radiation.

26 The diagram shows a heater above a thermometer. The thermometer bulb is in the position shown.

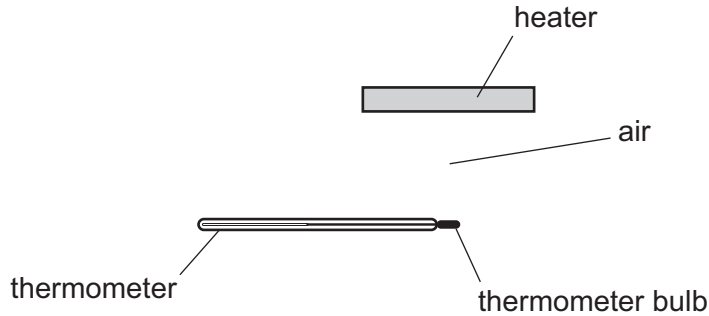

Which row shows how the heat energy from the heater reaches the thermometer bulb?

	conduction	convection	radiation
A	yes	yes	no
B	yes	no	yes
C	no	yes	no
D	no	no	yes

27 The diagram shows an air-conditioning unit on the wall of a room. The unit draws in warm air from the room and releases cold air into the room.

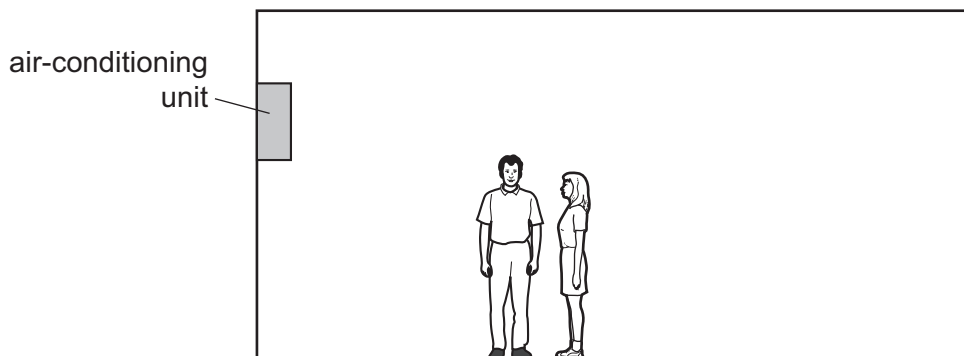

What happens to the cold air and why?

	cold air	why?
A	falls	it is less dense than warm air
B	falls	it is more dense than warm air
C	rises	it is less dense than warm air
D	rises	it is more dense than warm air

28 Which statement about thermal radiation is correct?

- A** It can only occur in a vacuum.
- B** It involves movement of electrons through a material.
- C** It involves movement of atoms.
- D** It is infra-red radiation.

29 The diagram shows a heater above a thermometer. The thermometer bulb is in the position shown.

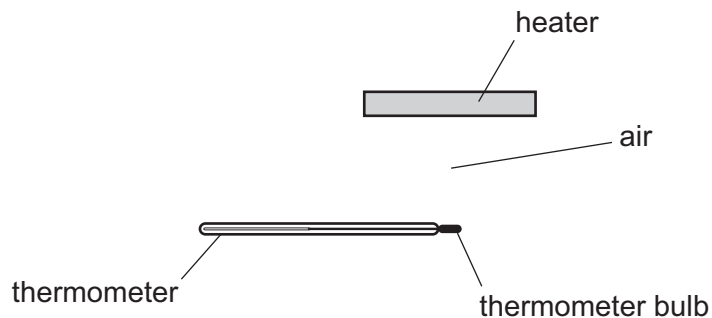

Which row shows how the heat energy from the heater reaches the thermometer bulb?

	conduction	convection	radiation
A	yes	yes	no
B	yes	no	yes
C	no	yes	no
D	no	no	yes

30 Which statement about the transfer of thermal energy is correct?

- A All metals conduct thermal energy equally well.
- B Convection can only occur in solids or liquids.
- C Convection occurs in liquids because hot liquid is more dense than cold liquid.
- D The radiation that transfers thermal energy is a type of electromagnetic radiation.

31 One type of double glazing consists of two panes of glass separated by a vacuum.

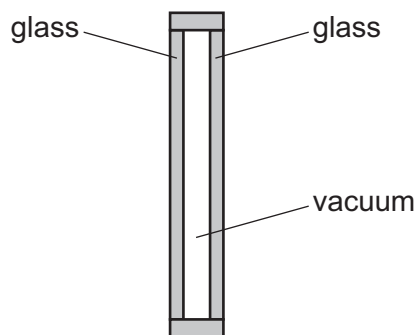

Which method or methods of energy transfer are prevented by the vacuum?

- A conduction and convection
- B conduction and radiation
- C convection and radiation
- D radiation only

32 The diagram shows a cooling unit in a refrigerator.

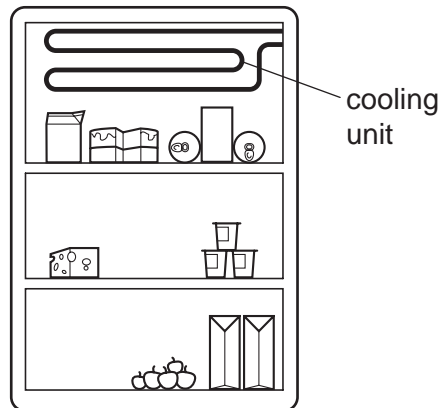

Why is the cooling unit placed at the top?

- A Cold air falls and warm air is displaced upwards.
- B Cold air is a bad conductor so heat is not conducted into the refrigerator.
- C Cold air is a good conductor so heat is conducted out of the refrigerator.
- D Cold air remains at the top and so prevents convection.

33 A heater is to be fitted in a room to warm the air throughout the room.

The diagram shows two possible positions to fit the heater, P and Q.

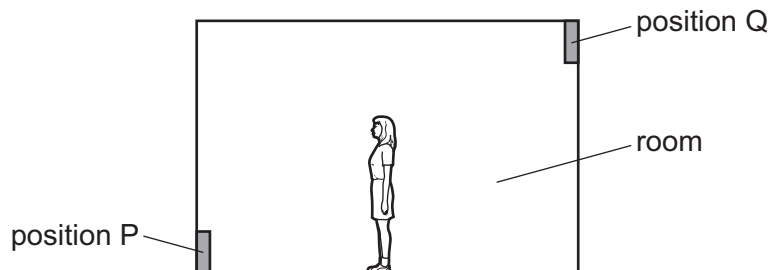

Which position is better and why?

	position	why
A	P	warmer air is less dense and rises
B	P	warmer air is more dense and rises
C	Q	warmer air is less dense and falls
D	Q	warmer air is more dense and falls

- 34 A piece of hot metal is held by a clamp in a cold room. The air next to the metal becomes hot. The density of the air changes and the air moves.

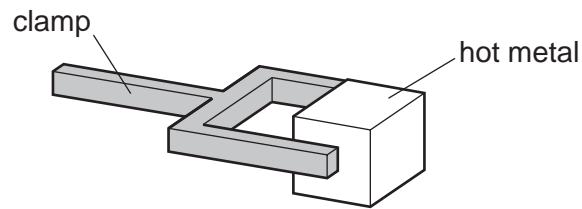

Which row shows the density change of the air and the direction in which the air moves?

	density of air	movement of air
A	decreases	downwards
B	decreases	upwards
C	increases	downwards
D	increases	upwards

- 35 A rod is made half of glass and half of copper. Four pins, **A**, **B**, **C** and **D** are attached to the rod by wax. The rod is heated in the centre as shown.

Which pin falls off first?

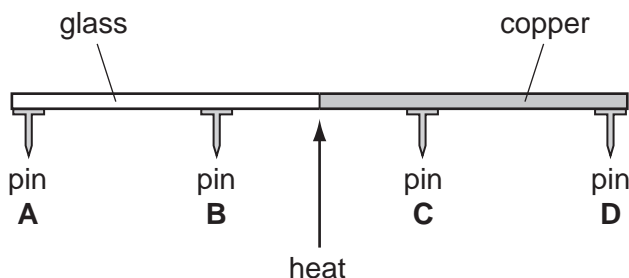

- 36 Why does convection take place in a liquid when it is heated?

- A Liquids expand when they are heated.
- B Liquids start to bubble when they get close to boiling point.
- C Molecules in the liquid expand when they are heated.
- D Molecules near to the surface of the liquid escape into the air.

- 37 Two plastic cups are placed one inside the other. Hot water is poured into the inner cup and a lid is put on top, as shown.

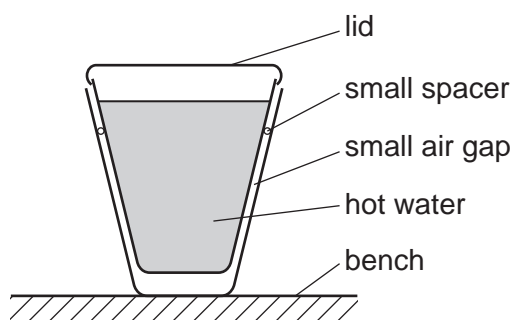

Which statement is correct?

- A Heat loss by radiation is prevented by the small air gap.
- B No heat passes through the sides of either cup.
- C The bench is heated by convection from the bottom of the outer cup.
- D The lid is used to reduce heat loss by convection.

38 An experiment is set up to find out which metal is the best conductor of heat.

Balls are stuck with wax to rods made from different metals, as shown in diagram 1.

The rods are heated at one end. Some of the balls fall off, leaving some as shown in diagram 2.

Which labelled metal is the best conductor of heat?

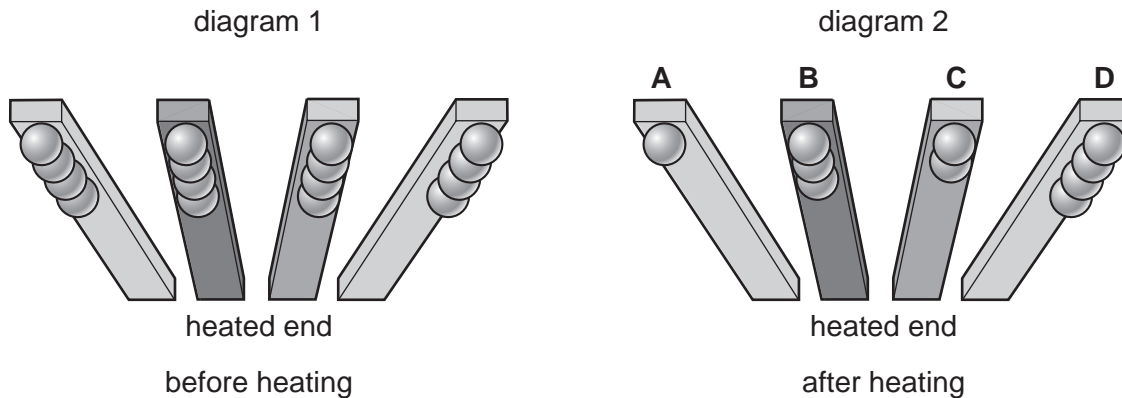

39 Food is kept in a cool-box which uses two ice packs to keep it cool.

Where should the ice packs be placed to keep all the food as cool as possible?

- A both at the bottom of the box
- B both at the top of the box
- C one at the front and one at the back of the box
- D one on the left and one on the right of the box

40 The diagram shows a cooling unit in a refrigerator.

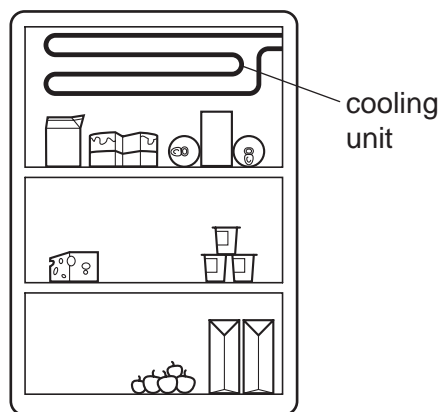

Why is the cooling unit placed at the top?

- A Cold air falls and warm air is displaced upwards.
- B Cold air is a bad conductor so heat is not conducted into the refrigerator.
- C Cold air is a good conductor so heat is conducted out of the refrigerator.
- D Cold air remains at the top and so prevents convection.

41 Two identical copper cans are filled with boiling water.

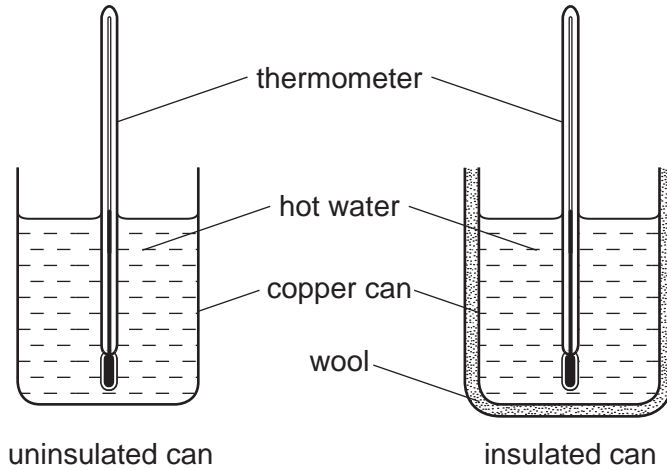

One can is insulated with wool. The temperature of the water in each can is taken every minute for several minutes. Graphs of the results are plotted.

Which graph shows the results obtained?

